

## God Heals Naaman

(2 Kings 5:1-19)

**"A final word: Be strong in the Lord and in his mighty power."**

(Ephesians 6:10)



## Wait and see...God is powerful

*If God is so powerful, why aren't all sick people healed?*

A day of wholeness and healing is coming...wait and see.

*If God is so powerful, why isn't there justice for everyone yet?*

A time for justice to rain down will come...wait and see.

*If God is so powerful, why aren't sad people joyful?*

A day will come when sadness has passed...wait and see.

*If God is so powerful, why aren't broken friendships fixed?*

A day when all that's broken and bitter will be healed is coming...wait and see.

Until then, we can do what Jesus says is most important: love God and love others. And we can trust God's perfect timing. Because God is great *and* good. And God always makes things right.

Wait and see.

### Talk-Starters

What's something you'd wait in line all day to do?

### Try-This-@-Home

It's Synchronize Your Clocks Day! Gather everyone together and go through every room making sure all clocks agree to the minute. Wall clocks, wristwatches, appliance clock displays, devices—get them all in agreement.

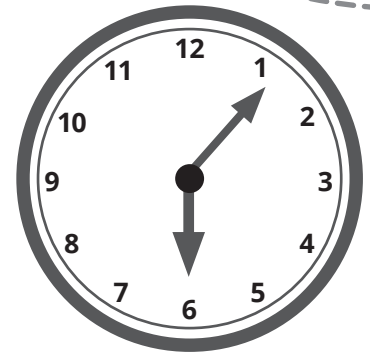

### Explore More @ Home

Wait on God—it's worth the wait! See Psalm 27:14 and Romans 8:25.



# Make this page fly home!

Fold a flyer. When you get home

...ask someone to wait exactly 37 seconds before launching it. Keep track of the time. Take turns, switching up the amount of time.

## Here's how:

1 Fold the paper in half as shown.



2 Fold in the top corners to the center to make flaps.

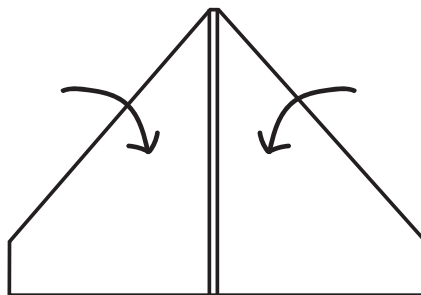

3 Flip over, then fold in one side about an inch from the center.

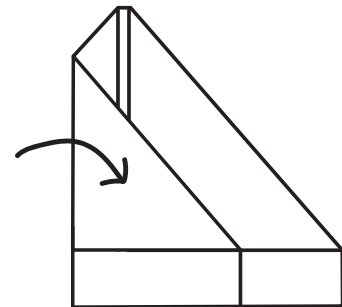

4 Unfold, then fold the other side about an inch from the center.

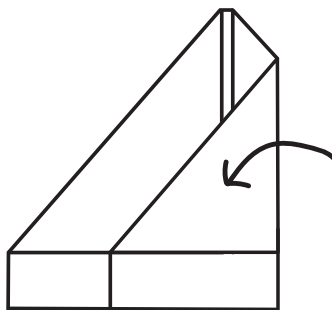

5 Flip over again, hold on to the center fold, and let 'er sail!

